



WAUPACA
ELEVATOR COMPANY, INC.
Specify the Specialists®

Planning Guide

Excelelevator™
Elevators





We are a proud member of the Accessibility Equipment Manufacturers Association. This symbol assures you of our commitment to high quality and accessibility to everyone.

Waupaca Elevator Mission Statement

Our company's mission is to supply and service products that meet or exceed our customers' expectations of high quality, value, delivery and longevity. Our success is a direct reflection of our employees' involvement and commitment to excellence. We strive to continuously improve our products to ensure meeting the future requirements of our customers and facilitate competitive growth.

Table of Contents

Introduction	4
Quick Guide to Elevators & Features	5-6
Elevator	7
Hoistway Layout	8-10
Hoistway Illustration	11
Hoistway Specifications	12
Machine Room	13
Elevator Equipment	14
Elevator Series 014	15



Introduction

This Planning Reference Guide is to be used as a guide in deciding the type of elevator to be installed, parameters of installation and steps taken to achieve a proper elevator installation. This guide may be used by the architect, contractor, dealer or home owner. The information in this guide is intended as an overview, each installation will have job specific specifications that must be followed. Do not attempt to construct a hoistway on this information alone.

Elevator installation is to be done by an authorized elevator contractor, and in accordance with installation instructions provided by the manufacturer. Installation must also be in compliance with requirements of the National Electric Code, American Society of Mechanical Engineers safety code, and state and local building codes. Waupaca Elevator's products are designed to meet the requirements of ASME - 17.1 National Elevator Codes for residential elevators and are fully certified by a registered professional engineer. Waupaca Elevator Company, Inc. elevators manufactured and installed under the proper parameters are warranted for 2 years. Manufacturer assumes no liability for equipment not installed in compliance with these codes.

Planning Steps

1. - Locate local dealer and together determine the following:
 - A - Select drive system, car type and design specifications
 - B - Address national, state and local code requirements
 - C - Hoistway size
 - D - Car size, layout and options
 - E - Machine room location and layout
 - F - Electrical requirements
2. - Obtain and follow site specific field drawings while building hoistway, doorways and any other construction related to the elevator.
3. - Coordinate with dealer to install elevator.



Elevator Quick Reference Guide

Mechanical Features		Winding Drum				J-SERIES	Hydraulic	
Weight Capacity	up to..	Standard 500 lbs.	PLC 500 lbs.	750 lbs. / 1,000 lbs.		Overhead Drum Paca-Glide 1,000 lbs.	750 lbs.	950 lbs.
Car Square Footage	inside dimensions... up to...	12 sq. ft.	12 sq. ft.	12 sq. ft. / 15 sq. ft.		15 sq. ft.	12 sq. ft.	15 sq. ft.
Travel / Stops	up to... / up to...	50' / 6	50' / 6	50' / 6		50' / 6	50' / 6	50' / 6
Speed	Feet per Minute	30	30	40		40	40	40
Pit Depth	Minimum depth	6"	6"	6"		6"	8"	8"
Overhead	above finished top floor w/ 6' 10" I.D. Cab	7' 6"	7' 10"	8' 0"		8' 10"	7' 10"	7' 10"
	above finished top floor w/ 7' 0" I.D. Cab	7' 8"	8'	8' 2"		9' 0"	8' 0"	8' 0"
	above finished top floor w/ 7' 4" I.D. Cab	8' 0"	8' 4"	8' 6"		9' 4"	8' 4"	8' 4"
	above finished top floor w/ 8' I.D. Cab	8' 8"	9' 0"	9' 2"		10' 0"	9' 0"	9' 0"
I.D.= Inside Dimensions								
Minimum Travel	Minimum travel allowed between stops	14"	18"	18"		18"	14"	14"
Electrical Requirements	230 volts, single phase, 60 hertz (seperate 120-volt circuit required - car lighting)	20 Amp	20 Amp	20 Amp		20 Amp	30 Amp	30 Amp
Controls	Magnetic Tape Reader and PLC	N/A	Standard	Standard		Standard	Standard	Standard
Auto Car Lighting		N/A	Standard	Standard		Standard	Standard	Standard
Homing Feature	Elevator will return to a predetermined location when not in use.	N/A	Optional	Optional		Standard	Standard	Standard
			NEED FLOOR LOCATION		FIELD PROGRAMMABLE			
Alarm	with Power Supply & Emergency Light	Optional	Optional	Optional		Standard	Standard	Standard
	with Battery	Standard	Standard	Standard		N/A	N/A	N/A
Easy Ryde		N/A	Standard	Standard		Standard	2 Speed Valve	2 Speed Valve
Operation	Manual Lowering Device	Standard	Standard	Standard		Standard	Standard	Standard
	Emergency Descent with Battery	N/A	N/A	Optional		Standard	Standard	Standard
	Round Trip with Battery	N/A	N/A	Optional		Optional	N/A	N/A

Design Features		Designer	Heritage	Estate	Estate Ltd	Custom Raised Panel**
Interior Walls	Standard	Birch or Melamine	Textured Loma Natural Hickory	Oak	Cherry	See Below
	Laminate (large selection)	Optional	N/A	N/A	N/A	N/A
	Oak	Optional	Optional Trim Only	Standard	Optional	Standard
	Maple, Cherry, Walnut or Mahogany	Optional	Optional Trim Only	Optional	Optional	Standard
	Exotic woods as available	N/A	N/A	N/A	N/A	Optional
With standard 500 lbs. units, only the Designer Car is available: - Birch - Oak - Maple - Melamine						
Interior Wall Finishes *	Standard	Unfinished	Textured Loma Natural Hickory	Unfinished/Nat. Medium/Dark	Estate Ltd. Blend	Unfinished/ Natural
	Lacquered (N/C = No Charge)	N/A	N/C Optional Trim Only	N/C Optional	N/C Optional	N/C Optional
Cab Height	Optional heights 6' 10", 7' 4" and 8' ID	7' 0" Std	7' 0" Std	7' 0" Std	7' 0" Std	7' 0" Std
Flooring	1" sub floor to accommodate a 1/4" flooring provided by builder/owner	Standard	Standard	Standard	Standard	Standard
Ceiling		Birch or Melamine	Textured Loma	Textured Loma	Cherry	Matches Walls
Lighting	4" down lights (additional lights available) Ring Colors: White, Black, Chrome or Brass	2	2	2	4	4
Gates	Accordion - Solid Vinyl: Chalk, White, Natural Oak or Light Oak	Standard	Standard	Standard	Optional	Optional
	Accordion - Non Standard Vinyl, Wood or Acrylic	Optional	Optional	Optional	Acrylic Standard	Acrylic Standard
Hall Stations	Call with "Fade Out" In Use ("Car Here" light is optional)	Standard	Standard	Standard	Standard	Standard
Car Operating Panel (COP)	Floor Buttons, Light Switch, Alarm Button and Emergency Stop Switch	Standard	Standard	Standard	Standard	Standard
Hall and COP Finishes	#4 Brushed Muntz or Stainless Steel	Standard	Standard	Standard	Optional	Optional
	#8 Polished Muntz or Stainless Steel	Optional	Optional	Optional	Standard	Standard
Handrail 1 per Car	Matching Wood	Standard	Standard	Standard	Optional	Optional
	Polished or Brushed, Brass or Chrome	Optional	Optional	Optional	Standard	Standard
Telephone Jack		Standard	Standard	Standard	Standard	Standard
Telephone Box	Flush Wood Cover or #4 or #8 Muntz or Stainless Steel Cover with phone	Optional	Optional	Optional	Optional	Optional

Handrails

#4 Brushed Brass Handrail w/ #8 Polished Ends & Standoffs
#8 Polished Brass Handrail w/ #8 Polished Ends & Standoffs
#4 Brushed Chrome Handrail w/ #8 Polished Ends & Standoffs
#8 Polished Chrome Handrail w/ #8 Polished Ends & Standoffs

Raised Panels

Choose from Ten Distinctive Designs or Create a Custom Design

** Raised Panel Designs are not available on 500 lbs. units

* Interior Wall Wood Finishes

Designer Car Birch: Unfinished only

Melamine: Natural Oak or White

Birch, Walnut, Maple, Mahogany & Exotic Woods: Unfinished or Natural

Oak: Unfinished, Natural, Medium or Dark

Cherry: Unfinished, Natural or Estate Ltd. Blend

Excelelevator™ Hydraulic Elevator

Series **014**

Advantages

- Reliable
- Quiet Operation
- Smooth Ride
- Emergency Battery Descent

The elevators listed in the following section are based upon our standard 12 sq. ft. car. Cars can be customized up to 15 sq. ft. on the 950 lb. unit.



Hoistway Layout - Excelelevator™

Construction Notes:

- Use specified rail backing from architect to frame into wall.
- Hoistways below show finished dimensions. Finished hoistway dimensions include drywall installation, plaster and paint.
- A maximum of 3" (see "F" below) are allowed between the closed hoistway door and the outer edge of the landing sill.
- Determine height of hall station by local code.
- Rough frame door.
- Shown below are the standard 12sq. ft. cars, size can be increased however some limitations will apply, see dealer for details.

The following examples are of a T601 Sling
(750 lbs. & 950 lbs. capacity)

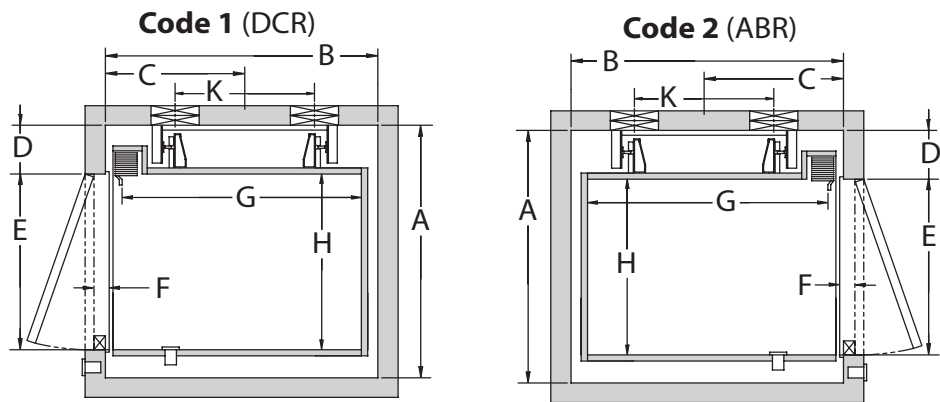

ELEVATOR HOISTWAY LAYOUT	HYDRAULIC ELEVATOR HOISTWAY DIMENSIONS									
	CAR SIZE	FINISHED HOISTWAY DIMENSIONS								
		A	B	C	D	E	F	G	H	K
Code 1 (DCR)	50.5" x 38"	51.75"	54.5"	27.25"	10.25"	36"	3"	48"	36"	27.5"
Code 2 (ABR)	50.5" x 38"	51.75"	54.5"	27.25"	10.25"	36"	3"	48"	36"	27.5"



Hoistway Layout - Excelelevator™

Continued

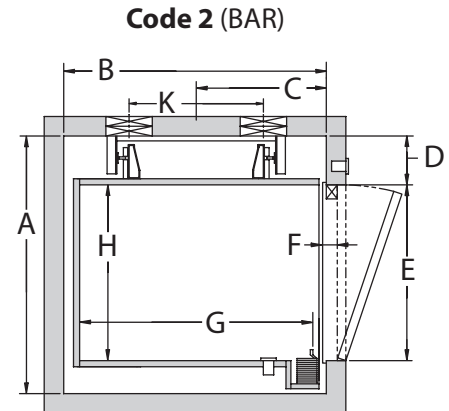
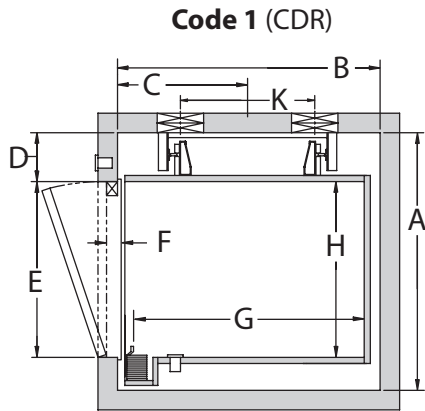

ELEVATOR HOISTWAY LAYOUT	HYDRAULIC ELEVATOR HOISTWAY DIMENSIONS									
	CAR SIZE	FINISHED HOISTWAY DIMENSIONS								
		A	B	C	D	E	F	G	H	K
Code 1 (CDR)	50.5" x 38"	52.75"	54.5"	27.25"	10.25"	36"	3"	48"	36"	27.5"
Code 2 (BAR)	50.5" x 38"	52.75"	54.5"	27.25"	10.25"	36"	3"	48"	36"	27.5"

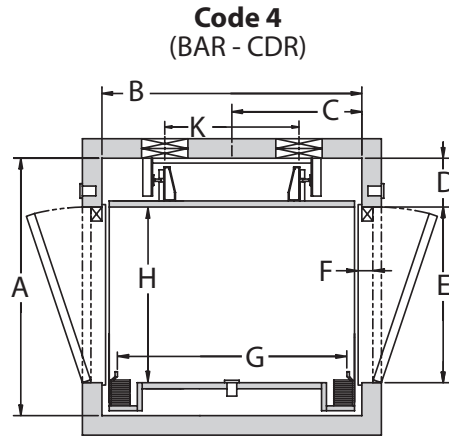
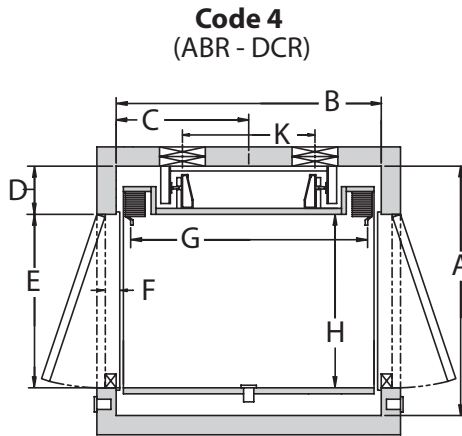

ELEVATOR HOISTWAY LAYOUT	HYDRAULIC ELEVATOR HOISTWAY DIMENSIONS									
	CAR SIZE	FINISHED HOISTWAY DIMENSIONS								
		A	B	C	D	E	F	G	H	K
Code 4 (ABR-DCR)	51" x 38"	51.75"	55"	27.5"	10.25"	36"	3"	48"	36"	27.5"
Code 4 (BAR-CDR)	51" x 38"	52.75"	55"	27.5"	10.25"	36"	3"	48"	36"	27.5"



Hoistway Layout - Excelelevator™

Continued

Code 6 (DCR - CB)

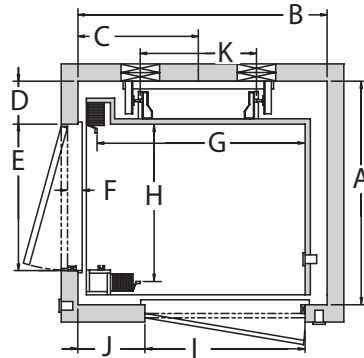

Code 5 (ABR - BC)

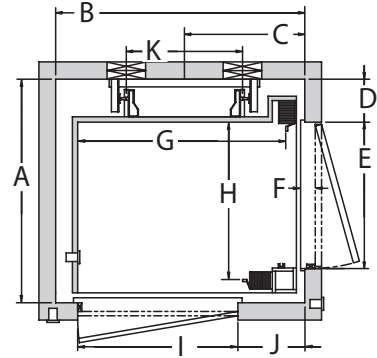

ELEVATOR HOISTWAY LAYOUT	HYDRAULIC ELEVATOR HOISTWAY DIMENSIONS											
	CAR SIZE	FINISHED HOISTWAY DIMENSIONS										
		A	B	C	D	E	F	G	H	I	J	K
Code 6 (DCR-CB)	50.5" x 38.5"	49.75"	56.5"	27.25"	10"	32"	3"	48"	36"	36"	15.5"	27.5"
Code 5 (ABR-BC)	50.5" x 38.5"	49.75"	56.5"	27.25"	10"	32"	3"	48"	36"	36"	15.5"	27.5"

FRONT OPENING RIGHT STACK (BC)

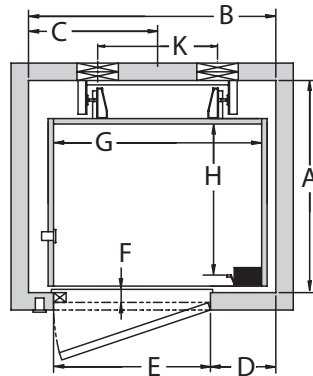

FRONT OPENING LEFT STACK (CB)

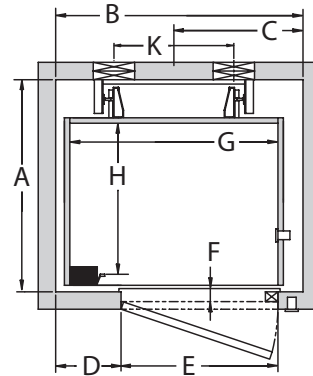

ELEVATOR HOISTWAY LAYOUT	HYDRAULIC ELEVATOR HOISTWAY DIMENSIONS									
	CAR SIZE	FINISHED HOISTWAY DIMENSIONS								
		A	B	C	D	E	F	G	H	K
Code 3 (BC)	50" x 38.5"	49.75"	56.5"	29.5"	15"	36"	3"	48"	36"	27.5"
Code 3 (CB)	50" x 38.5"	49.75"	56.5"	29.5"	15"	36"	3"	48"	36"	27.5"



Hoistway Illustrations - Excelelevator™

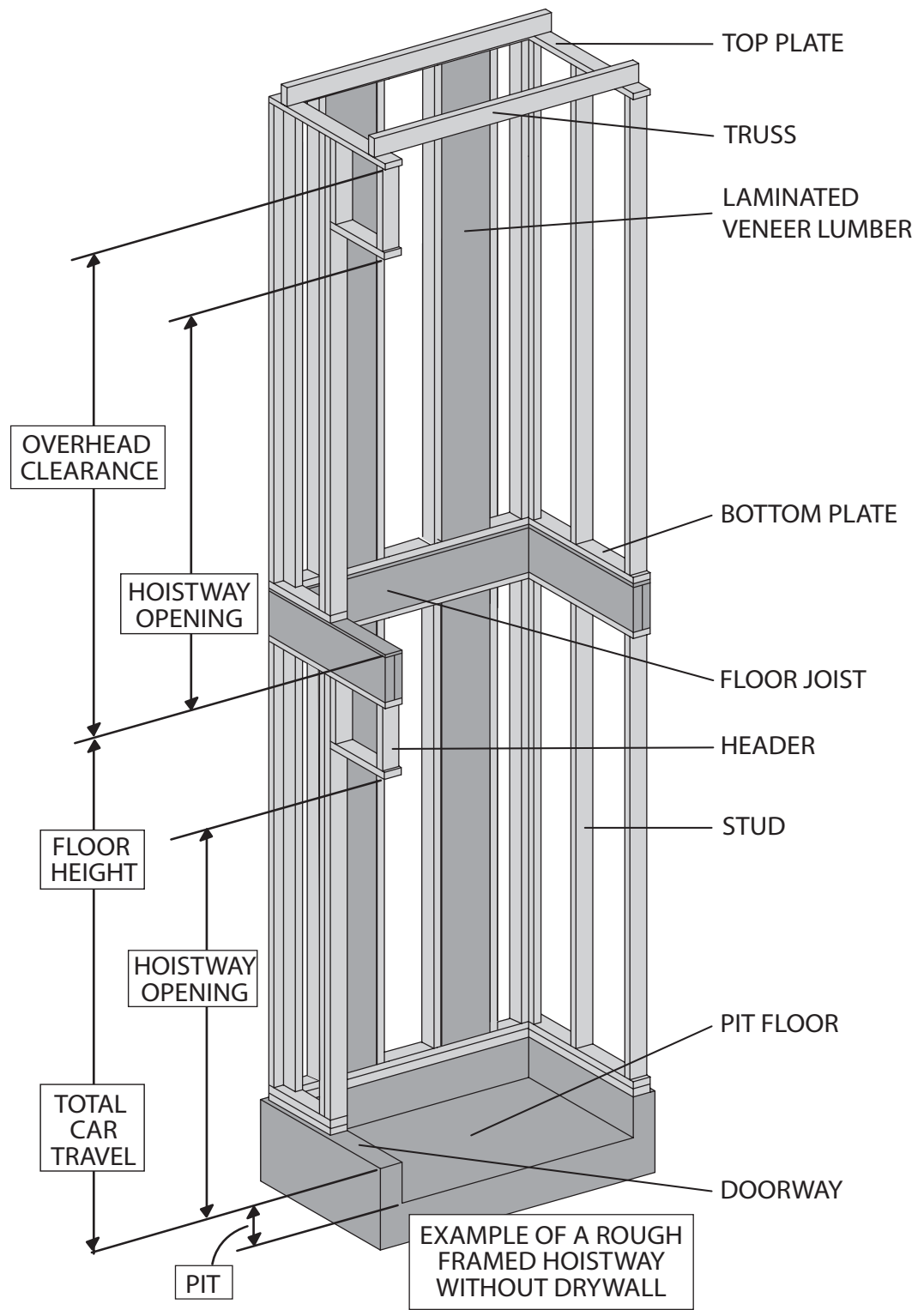

Hoistway Specifications - Excelelevator™

Refer to Illustration on previous page

ATTENTION CONSTRUCTION CONTRACTOR:

This is an example of a hoistway. Job specific documentation will be provided by Waupaca Elevator from which to construct the hoistway.

Hoistway Construction Requirements

(to be completed prior to elevator installation by contractor)

1. **Electrical Requirements:**

- Dedicated 208/230 Volts, 30 AMP Single Phase, 60 Hertz.
- A fused disconnect switch with branch 3 pole circuit wire to suit a 30 AMP service, fused for 20 AMP dual element (time delay fuse) with neutral.
- 115 Volt, 15 AMP single phase circuit for car lighting.
- Electrical wiring to comply with applicable codes.

2. **Unfinished/Un-installed Door** - Installation company may prefer a minimum of one hoistway door entrance and associated framing shall be left unfinished/un-installed to accommodate elevator installation equipment and to prevent accidental damage to door and framing (preferably at grade level).

3. **Plumb and Square Hoistway** - Hoistway must be plumb within 1/8 inch per 10 ft. of height and square at any point within 1/4 inch based on difference in diagonal measurements.

4. **Supportive Structure** - Structure must be capable of supporting the appropriate loads. (see previous page)

5. **Machine Room** - Machine room must be provided for operating equipment that meets national electric code clear space requirements and all local codes. Machine room must have a light switch and a convenience outlet. Temperature in machine room to be maintained between 50-100 ° F and relative humidity should not exceed 95%.

Access hole must be provided to route hydraulic hose or pipe(3/4" schedule 80) to hoistway.

6. **Telephone Connection** - Code requires a telephone connection to the elevator car therefore, a phone line must be installed in the machine room.

7. **ASME 17.1 Sec 5.3** - Hoistway to be constructed in accordance with ASME 17.1 Sec 5.3 and all local codes.

8. **Hoistway Door Security (Interlocks)** - All hoistway doors require interlocks as well as a door handle and a latch set. Interlocks will be installed by the elevator installers. Waupaca Elevator recommends the use of solid core doors.

9. **No Alterations** - Any alterations to the equipment without written authorization by Waupaca Elevator will void all warranties.

10. **Pit Floor Strength** - A pit floor must be designed to withstand an impact of 4150 lbs. per sq. ft. (minimum pit depth of 8").



Machine Room - Excelelevator™

Typical Machine Room Layout

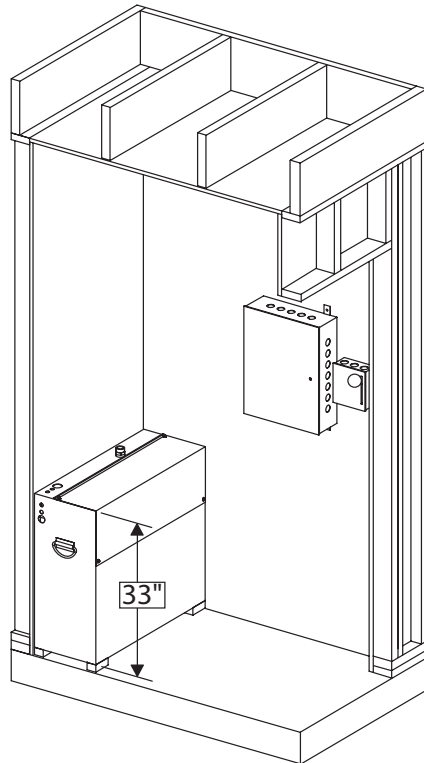

1. The Controller requires a clear minimum space of 36" x 30" located directly in front of the controller (refer to illustration).
2. A lockable service disconnect must be placed within sight of the controller and must be easily accessible from the latch side of the doorway.
3. A machine room or enclosure must be provided that meets national electrical code clear space requirements and all local codes. The machine room must contain a convenience outlet and light with switch. Temperatures in the machine room must be maintained between 50° - 100°F (with a relative humidity not to exceed 95%).

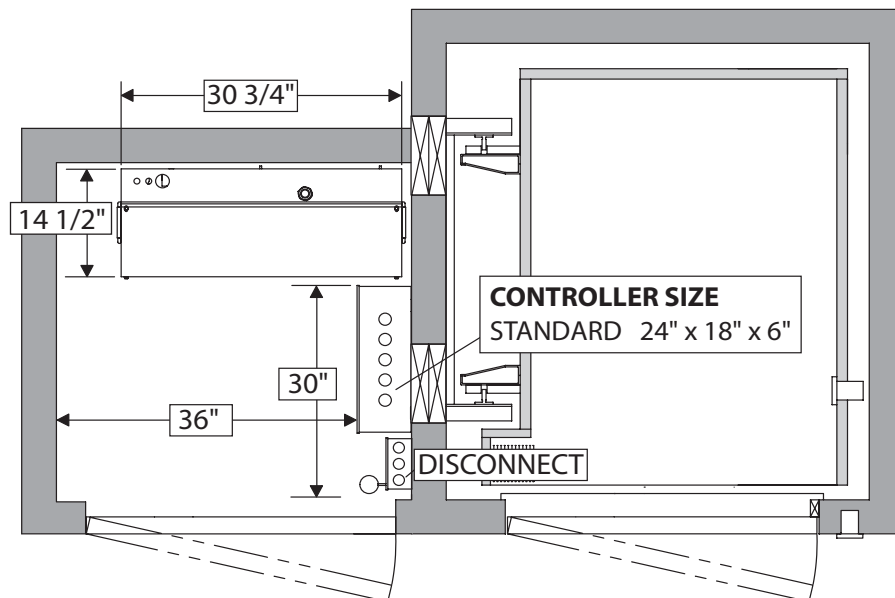

NOTE : THE MACHINE ROOM MAY BE PLACED ON ANY LEVEL OF THE HOME.



Elevator Equipment - Excelelevator™

Typical

- Pump Unit
- Slack Rope Safeties
- Interlocks
- Valve
- Stopping Devices
- Rail Segment

PUMP UNIT
 HAS A CONSTANT DISPLACEMENT ROTARY SCREW PUMP POWERED BY A 2 1/2 / 3 1/2 HORSEPOWER, 208/230 SINGLE PHASE MOTOR. OIL TANK REQUIRES APPROXIMATELY 30 GALLONS OF AW-32 HIGH GRADE HYDRAULIC OIL. MACHINE ROOM CAN BE LOCATED UP TO 40' AWAY, REQUIRES PIPING IN SOME AREAS.

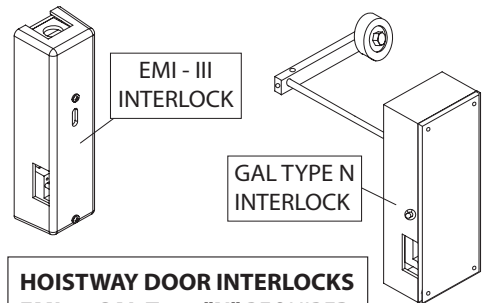
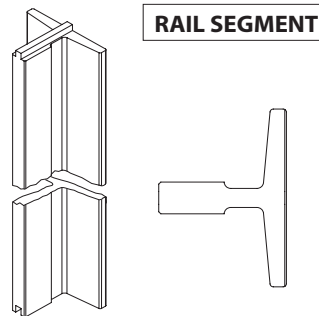
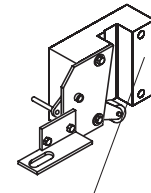
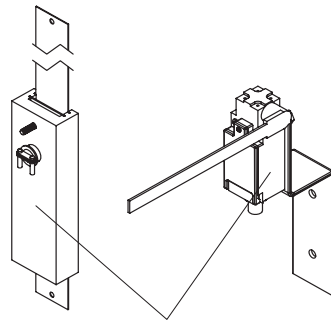
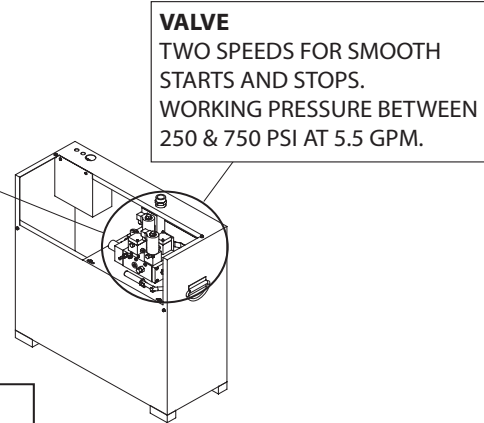

8 LBS. PER FOOT COMERCIAL ELEVATOR RAIL



Excelelevator™ Elevator Series 014

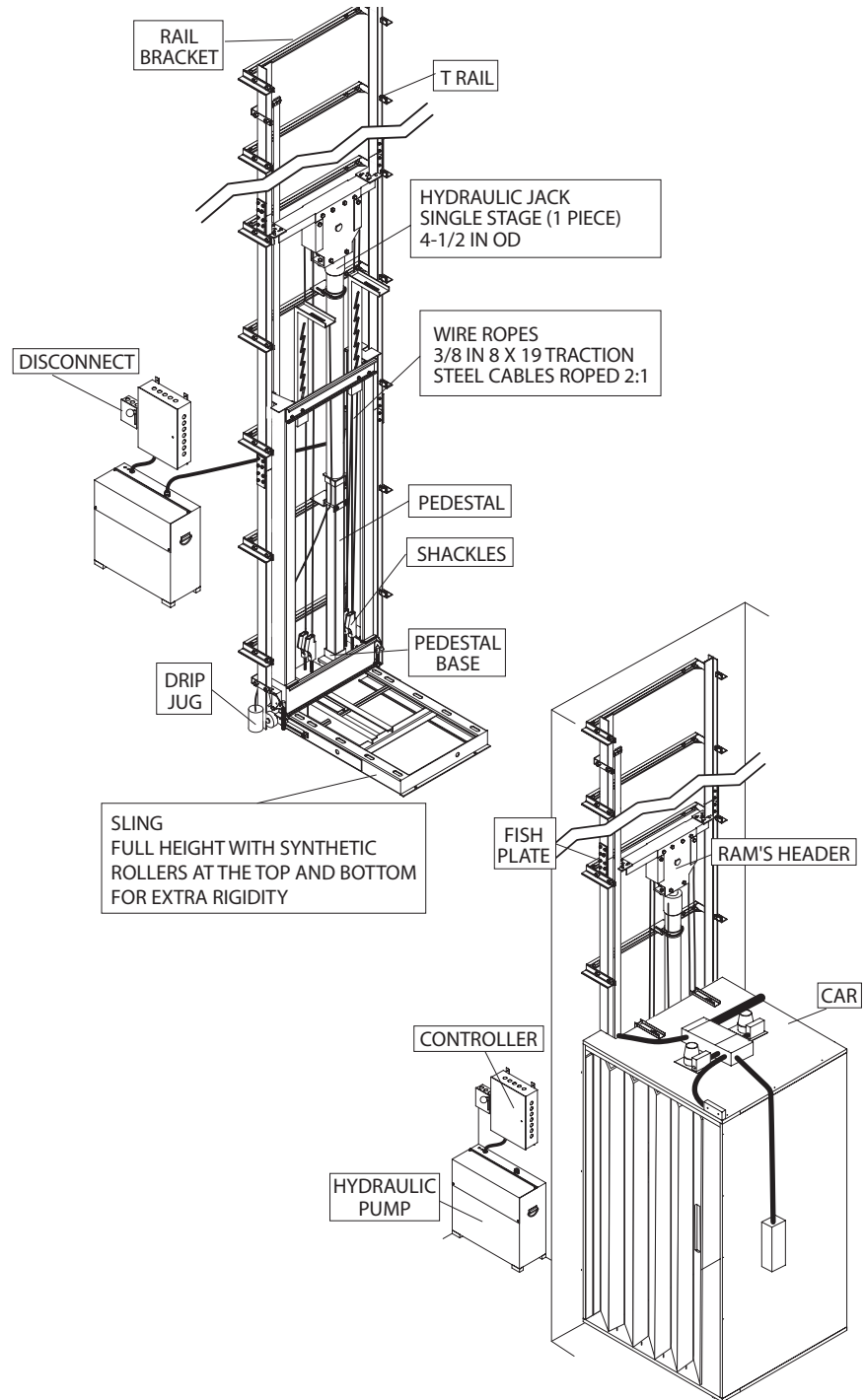



PMQ0200
MARCH 2006

1726 North Ballard Road • Appleton, WI 54911
Phone 920-991-9082 • www.waupacaelevator.com

