



**WAUPACA**  
**ELEVATOR** COMPANY, INC.  
Specify the Specialists®

---

# Planning Guide

---

**Paca-Glide**  
**Elevator**





We are a proud member of the Accessibility Equipment Manufacturers Association. This symbol assures you of our commitment to high quality and accessibility to everyone.

## Waupaca Elevator Mission Statement

Our company's mission is to supply and service products that meet or exceed our customers' expectations of high quality, value, delivery and longevity. Our success is a direct reflection of our employees' involvement and commitment to excellence. We strive to continuously improve our products to ensure meeting the future requirements of our customers and facilitate competitive growth.

## Table of Contents

Introduction .....	4
Quick Guide to Elevators & Features .....	5-6
Elevator .....	7
Hoistway Layout .....	8-10
Hoistway Illustration .....	11
Hoistway Specifications .....	12
Controller/Electrical Space .....	13
Elevator Equipment .....	14
Elevator Series 015 .....	15



---

## Introduction

This Planning Reference Guide is to be used as a guide in deciding the type of elevator to be installed, parameters of installation and steps taken to achieve a proper elevator installation. This guide may be used by the architect, contractor, dealer or home owner. The information in this guide is intended as an overview, each installation will have job specific specifications that must be followed. Do not attempt to construct a hoistway on this information alone.

Elevator installation is to be done by an authorized elevator contractor, and in accordance with installation instructions provided by the manufacturer. Installation must also be in compliance with requirements of the National Electric Code, American Society of Mechanical Engineers safety code, and state and local building codes. Waupaca Elevator's products are designed to meet the requirements of ASME - 17.1 National Elevator Codes for residential elevators and are fully certified by a registered professional engineer. Waupaca Elevator Company, Inc. elevators manufactured and installed under the proper parameters are warranted for 2 years. Manufacturer assumes no liability for equipment not installed in compliance with these codes.

---

## Planning Steps

1. - Locate local dealer and together determine the following:
  - A - Select drive system, car type and design specifications
  - B - Address national, state and local code requirements
  - C - Hoistway size
  - D - Car size, layout and options
  - E - Machine room location and layout (if required)
  - F - Electrical requirements
2. - Obtain and follow site specific field drawings while building hoistway, doorways and any other construction related to the elevator.
3. - Coordinate with dealer to install elevator.





# Elevator Quick Reference Guide

Mechanical Features		Winding Drum				J-SERIES	Hydraulic	
Weight Capacity	up to..	Standard 500 lbs.	PLC 500 lbs.	750 lbs. / 1,000 lbs.		Overhead Drum Paca-Glide 1,000 lbs.	750 lbs.	950 lbs.
Car Square Footage	inside dimensions... up to...	12 sq. ft.	12 sq. ft.	12 sq. ft. / 15 sq. ft.		15 sq. ft.	12 sq. ft.	15 sq. ft.
Travel / Stops	up to... / up to...	50' / 6	50' / 6	50' / 6		50' / 6	50' / 6	50' / 6
Speed	Feet per Minute	30	30	40		40	40	40
Pit Depth	Minimum depth	6"	6"	6"		6"	8"	8"
Overhead	above finished top floor w/ 6' 10" I.D. Cab	7' 6"	7' 10"	8' 0"		8' 10"	7' 10"	7' 10"
	above finished top floor w/ 7' 0" I.D. Cab	7' 8"	8'	8' 2"		9' 0"	8' 0"	8' 0"
	above finished top floor w/ 7' 4" I.D. Cab	8' 0"	8' 4"	8' 6"		9' 4"	8' 4"	8' 4"
	above finished top floor w/ 8' I.D. Cab	8' 8"	9' 0"	9' 2"		10' 0"	9' 0"	9' 0"
I.D.= Inside Dimensions								
Minimum Travel	Minimum travel allowed between stops	14"	18"	18"		18"	14"	14"
Electrical Requirements	230 volts, single phase, 60 hertz (seperate 120-volt circuit required - car lighting)	20 Amp	20 Amp	20 Amp		20 Amp	30 Amp	30 Amp
Controls	Magnetic Tape Reader and PLC	N/A	Standard	Standard		Standard	Standard	Standard
Auto Car Lighting		N/A	Standard	Standard		Standard	Standard	Standard
Homing Feature	Elevator will return to a predetermined location when not in use.	N/A	Optional	Optional		Standard	Standard	Standard
			NEED FLOOR LOCATION			FIELD PROGRAMMABLE		
Alarm	with Power Supply & Emergency Light	Optional	Optional	Optional		Standard	Standard	Standard
	with Battery	Standard	Standard	Standard		N/A	N/A	N/A
Easy Ryde		N/A	Standard	Standard		Standard	2 Speed Valve	2 Speed Valve
Operation	Manual Lowering Device On	Standard	Standard	Standard		Standard	Standard	Standard
	Emergency Descent with Battery	N/A	N/A	Optional		Standard	Standard	Standard
	Round Trip with Battery	N/A	N/A	Optional		Optional	N/A	N/A

Design Features		Designer	Heritage	Estate	Estate Ltd	Custom Raised Panel**
<b>Interior Walls</b>  <div style="border: 1px solid black; padding: 2px; font-size: small;">           With standard 500 lbs. units, only the Designer Car is available:            - Birch - Oak            - Maple - Melamine         </div>	Standard	Birch or Melamine	Textured Loma Natural Hickory	Oak	Cherry	See Below
	Laminate (large selection)	Optional	N/A	N/A	N/A	N/A
	Oak	Optional	Optional Trim Only	Standard	Optional	Standard
	Maple, Cherry, Walnut or Mahogany	Optional	Optional Trim Only	Optional	Optional	Standard
	Exotic woods as available	N/A	N/A	N/A	N/A	Optional
<b>Interior Wall Finishes *</b>	Standard	Unfinished	Textured Loma Natural Hickory	Unfinished/Nat. Medium/Dark	Estate Ltd. Blend	Unfinished/ Natural
	Lacquered (N/C = No Charge)	N/A	N/C Optional Trim Only	N/C Optional	N/C Optional	N/C Optional
<b>Cab Height</b>	Optional heights 6' 10", 7' 4" and 8' ID	7' 0" Std	7' 0" Std	7' 0" Std	7' 0" Std	7' 0" Std
<b>Flooring</b>	1" sub floor to accommodate a 1/4" flooring provided by builder/owner	Standard	Standard	Standard	Standard	Standard
<b>Ceiling</b>		Birch or Melamine	Textured Loma	Textured Loma	Cherry	Matches Walls
<b>Lighting</b>	4" down lights (additional lights available) Ring Colors: White, Black, Chrome or Brass	2	2	2	4	4
<b>Gates</b>	Accordion - Solid Vinyl: Chalk, White, Natural Oak or Light Oak	Standard	Standard	Standard	Optional	Optional
	Accordion - Non Standard Vinyl, Wood or Acrylic	Optional	Optional	Optional	Acrylic Standard	Acrylic Standard
<b>Hall Stations</b>	Call with "Fade Out" In Use ("Car Here" light is optional)	Standard	Standard	Standard	Standard	Standard
<b>Car Operating Panel (COP)</b>	Floor Buttons, Light Switch, Alarm Button and Emergency Stop Switch	Standard	Standard	Standard	Standard	Standard
<b>Hall and COP Finishes</b>	#4 Brushed Muntz or Stainless Steel	Standard	Standard	Standard	Optional	Optional
	#8 Polished Muntz or Stainless Steel	Optional	Optional	Optional	Standard	Standard
<b>Handrail 1 per Car</b>	Matching Wood	Standard	Standard	Standard	Optional	Optional
	Polished or Brushed, Brass or Chrome	Optional	Optional	Optional	Standard	Standard
<b>Telephone Jack</b>		Standard	Standard	Standard	Standard	Standard
<b>Telephone Box</b>	Flush Wood Cover or #4 or #8 Muntz or Stainless Steel Cover with phone	Optional	Optional	Optional	Optional	Optional

### Handrails

#4 Brushed Brass Handrail w/ #8 Polished Ends & Standoffs  
 #8 Polished Brass Handrail w/ #8 Polished Ends & Standoffs  
 #4 Brushed Chrome Handrail w/ #8 Polished Ends & Standoffs  
 #8 Polished Chrome Handrail w/ #8 Polished Ends & Standoffs

### \* Interior Wall Wood Finishes

**Designer Car Birch:** Unfinished only

**Melamine:** Natural Oak or White

**Birch, Walnut, Maple, Mahogany & Exotic Woods:** Unfinished or Natural

**Oak:** Unfinished, Natural, Medium or Dark

**Cherry:** Unfinished, Natural or Estate Ltd. Blend

### Raised Panels

Choose from Ten Distinctive Designs or Create a Custom Design

\*\* Raised Panel Designs are not available on 500 lbs. units

---

# Paca-Glide

## Winding Drum Elevator

### Machine Room Less

Series **015**

#### Advantages

- No Machine Room Required
- Decreased Installation Time
- Advanced Fieldbus Electrical System
- Reliable
- Quiet Operation
- Smooth Ride
- Emergency Battery Descent
- Automatic Gate Operator

The elevators listed in the following section are based upon our standard 12 sq. ft. car. Cars can be customized up to 15 sq. ft.



# Hoistway Layout - Paca-Glide

## Construction Notes:

- Use specified rail backing from architect to frame into wall.
- Hoistways below show finished dimensions. Finished hoistway dimensions include drywall, plaster and paint.
- A maximum of 3" (see "G" below) are allowed between the closed hoistway door and the outer edge of the landing sill.
- Determine height of hall station by local code.
- Rough frame door in place with an extra inch of space on each side of the door to allow for door installation.
- Shown below are the standard 12sq. ft. cars (size can be increased but some limitations will apply, see dealer for details).

The following examples are of a 1,000 lb. unit.

Elevators are illustrated with accordion gates.

The following layouts were designed for travel less than 25 feet, for distances up to 50 feet contact Waupaca Elevator Co.

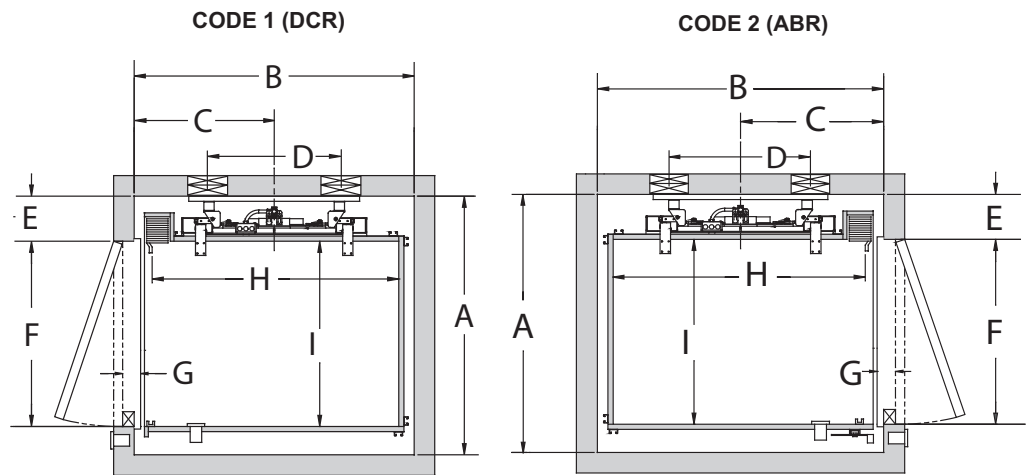

ELEVATOR HOISTWAY LAYOUT	CAR SIZE	PACA GLIDE ELEVATOR HOISTWAY DIMENSIONS								
		FINISHED HOISTWAY DIMENSIONS								
		A	B	C	D	E	F	G	H	I
CODE 1 (DCR)	48" x 36"	50.25"	54.5"	27.25"	24.5"	8.75"	36"	3"	48"	36"
CODE 2 (ABR)	48" x 36"	50.25"	54.5"	27.25"	24.5"	8.75"	36"	3"	48"	36"



# Hoistway Layout - Paca-Glide

## Continued

CODE 1 (CDR)

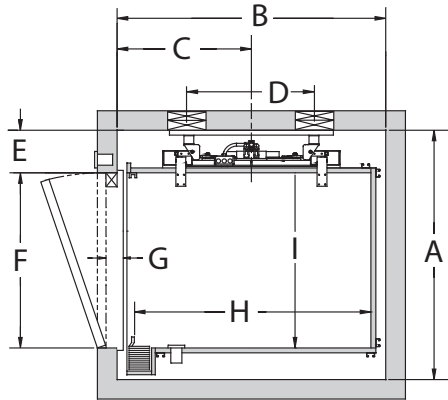

CODE 2 (BAR)

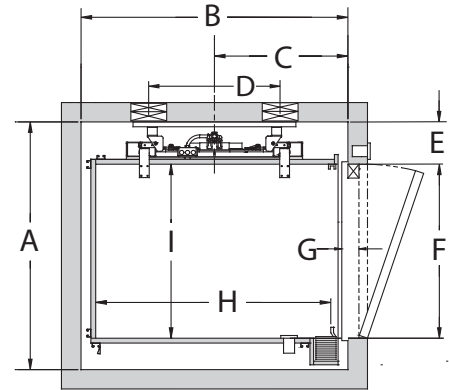

ELEVATOR HOISTWAY LAYOUT	PACA GLIDE ELEVATOR HOISTWAY DIMENSIONS									
	CAR SIZE	FINISHED HOISTWAY DIMENSIONS								
		A	B	C	D	E	F	G	H	I
CODE 1 (CDR)	48" x 36"	51.25"	54.5"	27.25"	24.5"	8.75"	36"	3"	48"	36"
CODE 2 (BAR)	48" x 36"	51.25"	54.5"	27.25"	24.5"	8.75"	36"	3"	48"	36"

CODE 4  
(ABR - DCR)

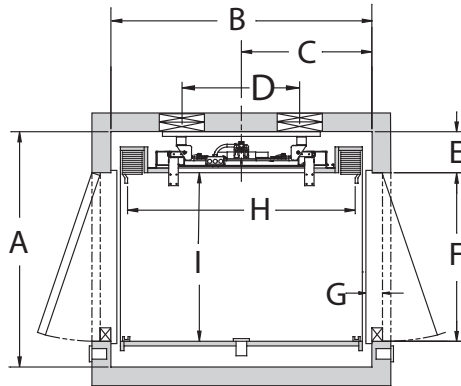

CODE 4  
(BAR - CDR)

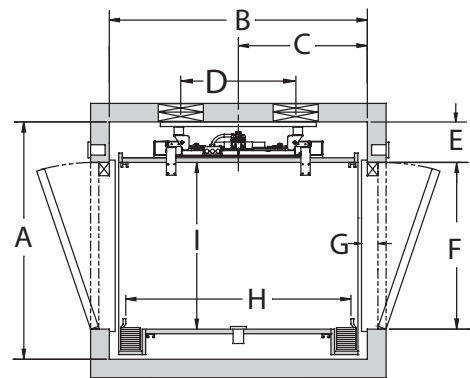

ELEVATOR HOISTWAY LAYOUT	PACA GLIDE ELEVATOR HOISTWAY DIMENSIONS									
	CAR SIZE	FINISHED HOISTWAY DIMENSIONS								
		A	B	C	D	E	F	G	H	I
CODE 4 (ABR-DCR)	48" x 36"	50.25"	55"	27.50"	24.5"	8.75"	36"	3"	48"	36"
CODE 4 (BAR-CDR)	48" x 36"	51.25"	55"	27.50"	24.5"	8.75"	36"	3"	48"	36"



# Hoistway Layout - Paca-Glide

Continued

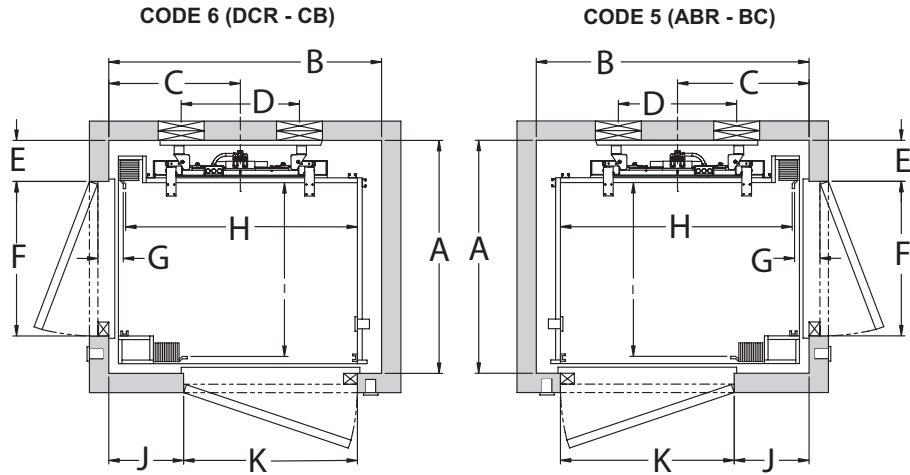

ELEVATOR HOISTWAY LAYOUT	PACA GLIDE ELEVATOR HOISTWAY DIMENSIONS											
	CAR SIZE	FINISHED HOISTWAY DIMENSIONS										
		A	B	C	D	E	F	G	H	I	J	K
CODE 6 (DCR-CB)	48" x 36"	48.25"	56.5"	27.25"	24.5"	8.5"	32"	3"	48"	36"	15.5"	36"
CODE 5 (ABR-BC)	48" x 36"	48.25"	56.5"	27.25"	24.5"	8.5"	32"	3"	48"	36"	15.5"	36"

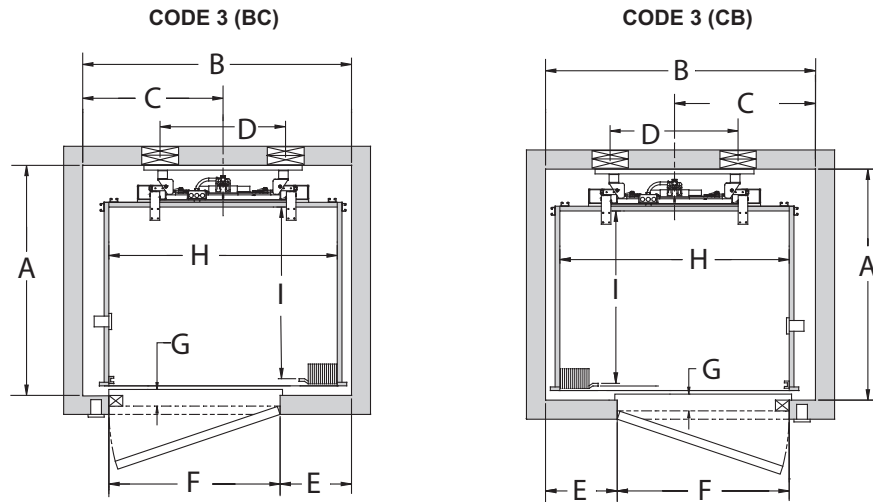

ELEVATOR HOISTWAY LAYOUT	PACA GLIDE ELEVATOR HOISTWAY DIMENSIONS									
	CAR SIZE	FINISHED HOISTWAY DIMENSIONS								
		A	B	C	D	E	F	G	H	I
CODE 3 (BC)	48" x 36"	48.25"	56.5"	29.5"	24.5"	15"	36"	3"	48"	36"
CODE3 (CB)	48" x 36"	48.25"	56.5"	29.5"	24.5"	15"	36"	3"	48"	36"



# Hoistway Illustrations - Paca-Glide

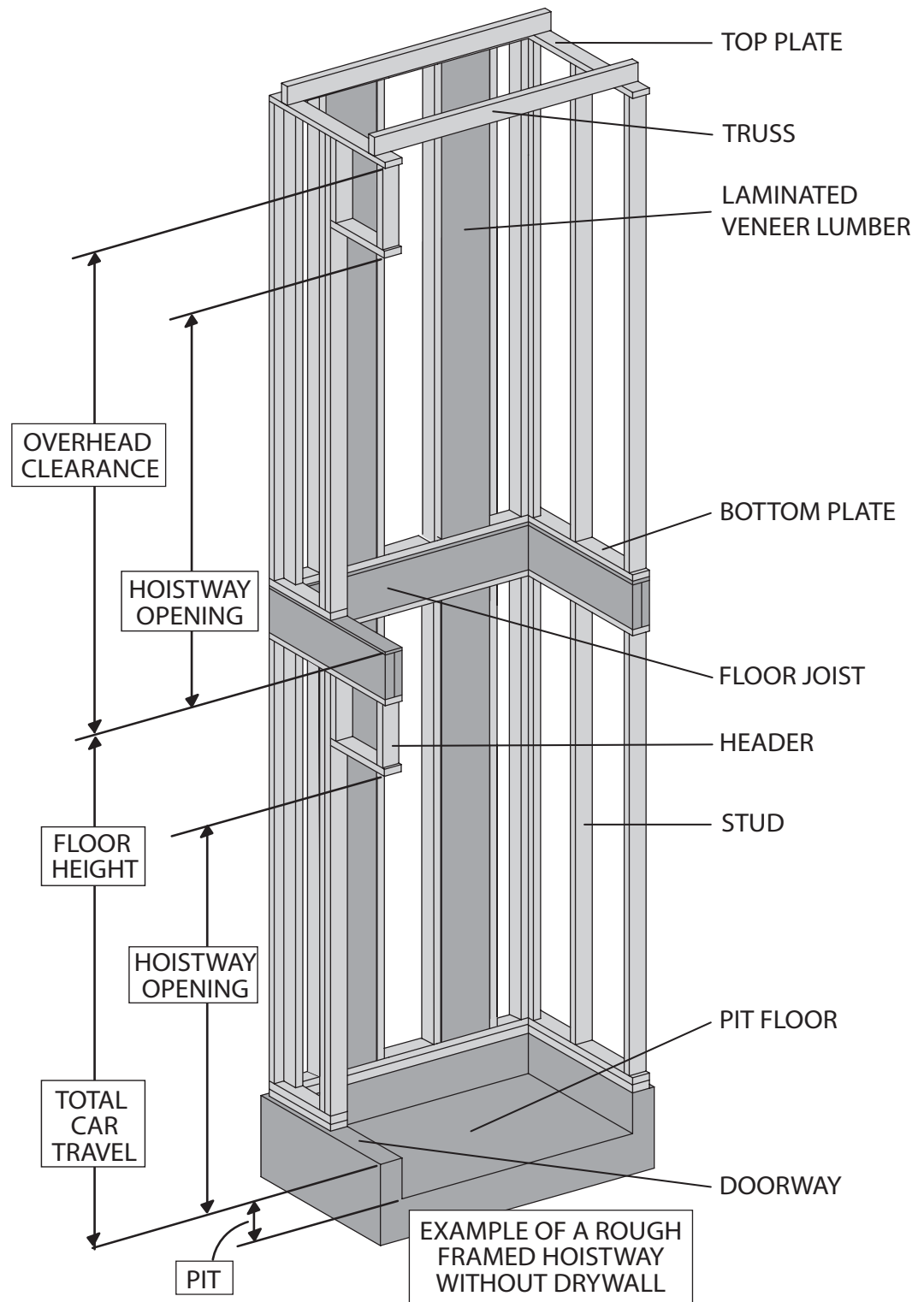

# Hoistway Specifications - Paca-Glide®

Refer to Illustration on previous page

## ATTENTION CONSTRUCTION CONTRACTOR:

This is an example of a winding drum hoistway. Job specific documentation will be provided by Waupaca Elevator from which to construct the hoistway.

## Hoistway Construction Requirements

(to be completed prior to elevator installation by contractor)

- 1. Electrical Requirements:**
  - Dedicated 230 VAC 30 AMP Circuit Single Phase. Fuse should be a time delay 20 AMP.
  - Power supply to be installed in a lockable fused disconnect.
  - 120 VAC 15 Amp Circuit Single Phase with manual disconnect & 15 AMP fuse.
  - Electrical wiring to comply with applicable codes.
- 2. Unfinished/Un-installed Door** - Installation company may prefer a minimum of one hoistway door entrance and associated framing shall be left unfinished/un-installed to accommodate elevator installation equipment and to prevent accidental damage to door and framing (preferably at grade level).
- 3. Plumb and Square Hoistway** - Hoistway must be plumb within 1/8 inch per 10 ft. of height and square at any point within 1/4 inch based on difference in diagonal measurements.
- 4. Supportive Structure** - Structure must be capable of supporting the appropriate loads. Local engineering support is recommended.
- 5. Telephone Connection** - Code requires a telephone connection to the elevator car, therefore, a phone line must be installed leading to the controller.
- 6. ASME 17.1 Part 5.3** - Hoistway to be constructed in accordance with ASME17.1 Part 5.3 and all local codes.
- 7. Hoistway Door Security (Interlocks)** - All hoistway doors require interlocks as well as a door handle and a latch set. Interlocks will be installed by the elevator installers. Waupaca Elevator recommends the use of solid core doors.
- 8. Temperature Requirements** - Hoistway and machine room (if applicable) temperature should be maintainable between 50° F- 100° F and should not be exposed to the elements.
- 9. No Alterations** - Any alterations to the equipment without written authorization by Waupaca Elevator will void all warranties.
- 10. Pit Floor Strength** - A pit floor must be designed to withstand a load of 4,000 lbs. per sq. ft. When used, concrete must be a minimum of 4" thick and rated at 3500PSI.



# Controller Space - Paca-Glide

## Typical Layout

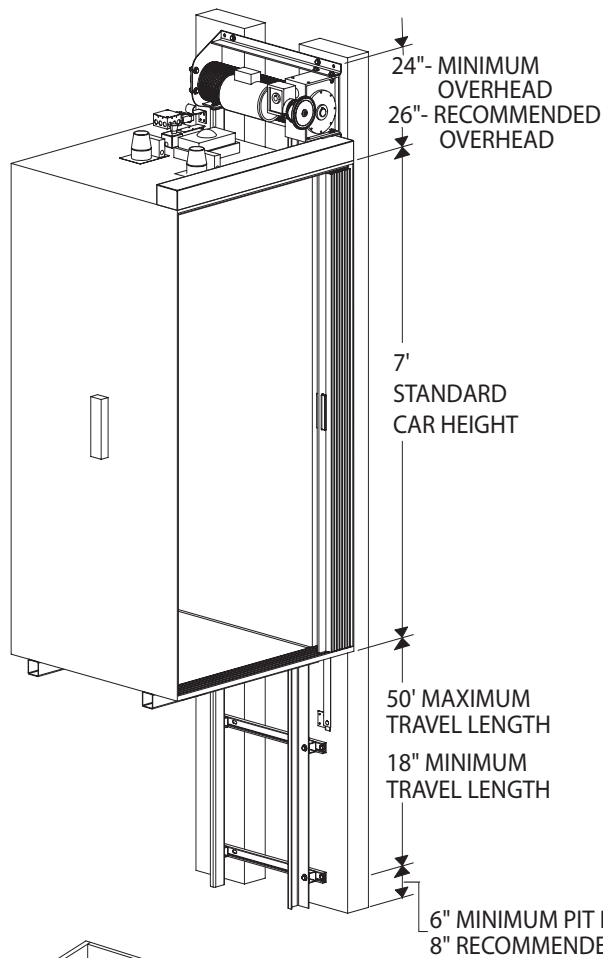

1. The Controller requires a clear minimum space of 36" x 30" located directly in front of the controller (refer to illustration).
2. A lockable service disconnect must be placed within sight of the controller and must be easily accessible, from the latch side of the doorway (if door is present).
3. Controller Space must be provided for the operating equipment that meets national electrical code clear space requirements and all local codes. Must provide a convenience outlet and light with switch. Temperatures must be maintained between 50°-100°F (with a relative humidity not to exceed 95%).

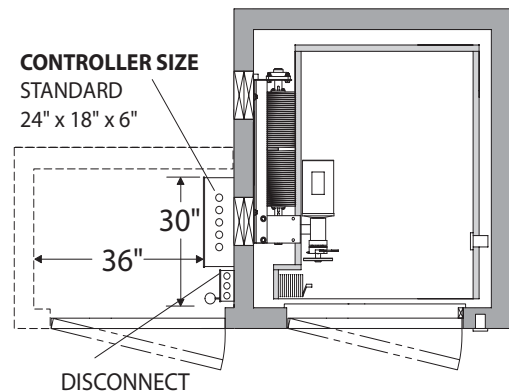
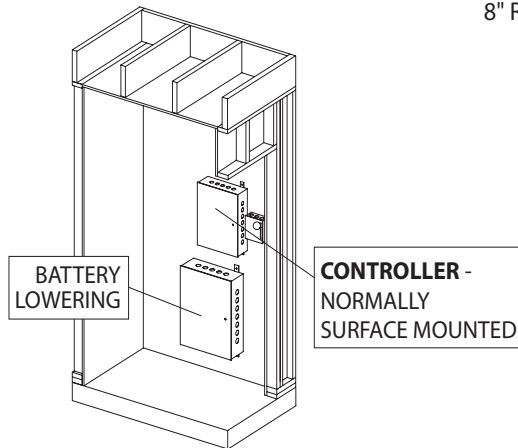

# Elevator Equipment - Paca-Glide

## Typical

- Powerhead
- Interlocks
- Main Rail
- Motor
- Gear Box
- Drum

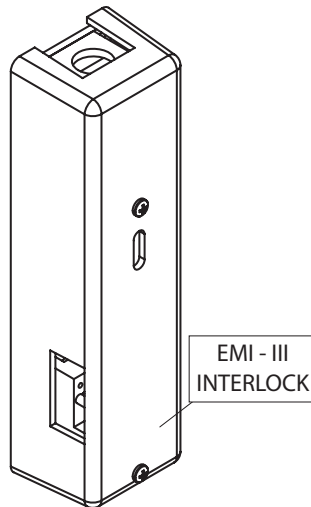
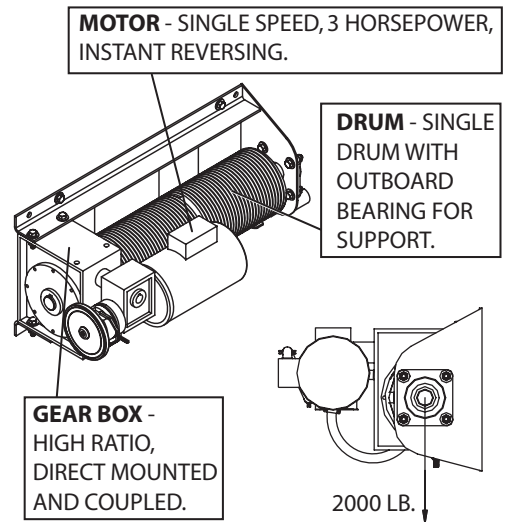
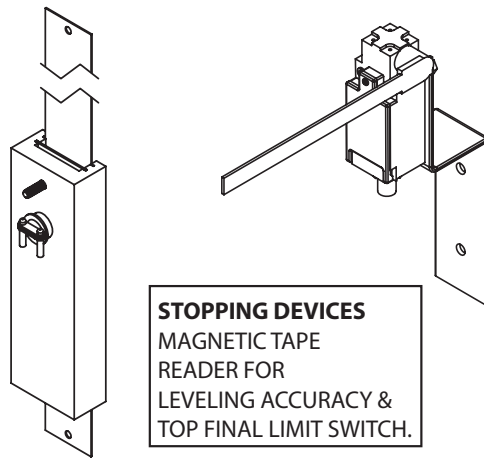

**HOISTWAY DOOR INTERLOCKS EMI** required at each opening to prevent hoistway or elevator access while elevator is operating or at another landing.

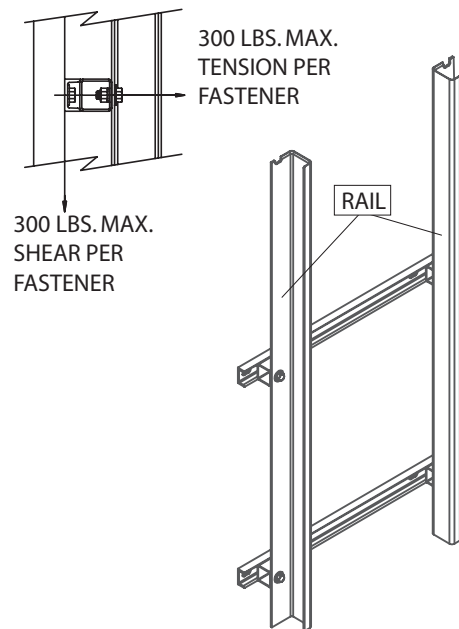

# Paca-Glide Elevator Series 015

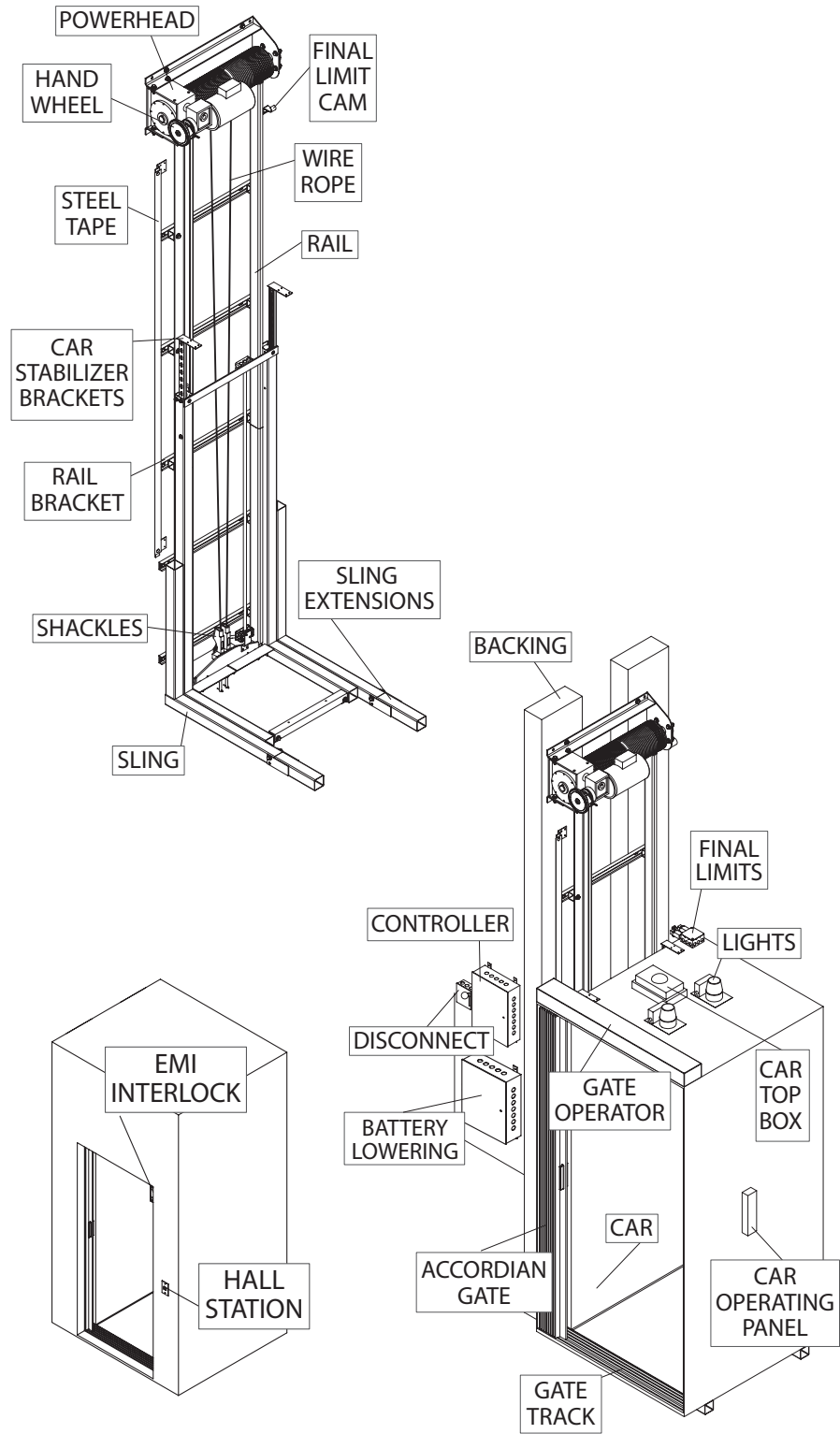



PMQ0300  
APRIL 2006

1726 North Ballard Road • Appleton, WI 54911  
Phone 920-991-9082 • [www.waupacaelevator.com](http://www.waupacaelevator.com)

